

Press Release 05 | 22

Topic	Product News
Headline	World Premiere at InnoTrans 2022
Sub-headline	ESCHA shows valve connectors with general rail approval
Date	28 June 2022
Characters (incl. blanks)	3.222
Link for add'l information	www.escha.net/en

Halver, 28 June 2022 – The German connectivity specialist ESCHA shows a world premiere at the international leading trade fair InnoTrans from 20 to 23 September in Berlin. For the first time, the company shows pre-assembled and overmolded valve connectors with general rail approval meeting the high security standards according to DIN EN 45545-2 (fire performance) and DIN EN 50155 (shock, vibration and mechanical stresses). So far, there have only been field-wireable alternatives or overmolded connectors, where only the cable is approved for the use in the rail industry. ESCHA is the first manufacturer offering overmolded valve connectors with a general approval for this demanding market. Compared to the field-wireable variants, these offer the advantage that they are more reliable, easier – and above all – quicker to install. The new valve connectors will be available in different designs right from the market launch and complement the comprehensive product range called «rail approved», which ESCHA has developed specifically for the bus- and rail industry.

High number of variants

The new rail-specific valve connectors from ESCHA can be ordered in different versions directly after the InnoTrans. As a standard, the A, B, BI, C and CI housing styles are equipped with a threaded grip body for protective hoses. The protective hose protects the cable against damage by stone chip and pollution on train exteriors. In addition, the valve connectors are available with LED status display as well as protective circuit. Different cable diameters complete the range. Of course, all variants meet the high requirements according to protection classes IP65, IP67 and IP68.

The right connectivity for every level

The current «rail approved» product range from ESCHA comprises connectivity solutions for four various wiring levels. For the Ethernet-Train-Backbone level (IEC 61375-2-5), ESCHA

offers components with data transmission rates up to 10Gbit/sec (Cat6A). For the second level – the Ethernet Consist Network (ECN) according to IEC 61375-3-4 – components with data transmission rates up to 100Mbit/sec (Cat5e) are used. As to the sensor-/actuator wiring on the third level, ESCHA offers M8- and M12-connectors, which will now be complemented by the new valve connectors. For power supply on the fourth wiring level, ESCHA has selected single-ended and double-ended cord sets with S-coding out of the «M12 POWER» product range. They have been adjusted to the typically high rail industry requirements and are particularly adapted for alternating current applications (AC-applications up to 12A / 630V).

Industry-specific add-on services

In order to accommodate the individual rail industry requirements, ESCHA does not specify any standard cable lengths in case of «rail approved» items and supplies inch-perfect. In addition to kitting, labelling and further services facilitating on-board installations, ESCHA offers customer-specific cable harnesses to easily realize complex wiring structures. With the possibility of different specifications for individual wagons. Visitors to stand 250 in hall 12 of the Berlin fairground can obtain information on these topics and the possibilities of customer-specific individual developments.

Photos | Caption



ESCHA PI0522_1: The new valve connectors from ESCHA are celebrating their world premiere at the InnoTrans 2022 in Berlin and have a general rail approval.

Source: ESCHA GmbH & Co. KG

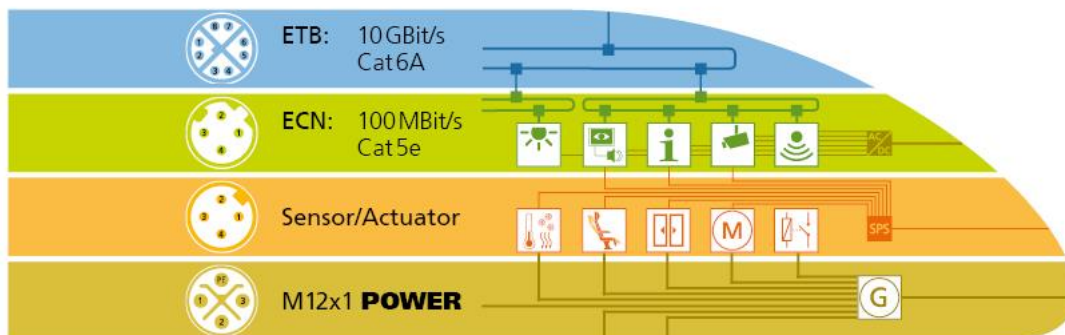

ESCHA PI0522_2: ESCHA offers high-grade connectivity for the four typical wiring levels in trains.

Source: ESCHA GmbH & Co. KG

About us

The ESCHA Group is a leading supplier in the field of industrial connectivity. For more than 35 years, the family-controlled company has been developing and manufacturing innovative product novelties taking dynamics to the market for automation components. Based on its standard products, the company designs custom-made connectivity and individual special solutions. With about 840 employees around the globe and highly in-depth development and production, ESCHA is extending its product portfolio constantly and independently. The consolidated group turnover in 2021 amounts to 87 million Euros. ESCHA guarantees high availability and consistent quality of its products worldwide through production facilities in Germany, Czech Republic, Hungary and China as well as licensed production in USA and Mexico.

Reader Contact

ESCHA GmbH & Co. KG
Elberfelder Straße 32 | 58553 Halver/Germany

Phone: +49 2353 708-800
Fax: +49 2353 708-8410
Internet: www.escha.net
Email: info@escha.net

Media Contact

ESCHA GmbH & Co. KG
Florian Schnell
Director Marketing
Elberfelder Straße 32 | 58553 Halver/Germany

Phone: +49 2353 708-8156
Mobile: +49 151 14192185
Email: f.schnell@escha.net