

Delivery regulations

Delivery regulations for cables

Contents

1. Goal | purpose
2. Scope of validity
3. Delivery date and delays
4. Delivery packaging, palletization and weight
 - 4.1 Delivery packaging
 - 4.2 Palletization | load carriers
 - 4.3 Loading of the pallets
5. Delivery note
6. Delivery, dispatch type
7. Document owner

Electronically archived document, legally valid without a signature.
Duplication is not subject to the updating service.

1. Goal | purpose

For processing of deliveries of cables without delay and as easily as possible, for storage in our warehouse and processing in production it is of utmost importance that the following requirements and conditions are fulfilled starting immediately, unless otherwise agreed.

ESCHA reserves the right to send back completely or in part deficient goods deliveries with a test report, the cost for which is borne by the contractor (supplier), if these delivery regulations are repeatedly or seriously breached.

2. Scope of validity

- These delivery regulations apply to all deliveries of cable.
- Exception: Contractual regulations agreed to on an individual basis (e.g. with system suppliers, logistics partners).

3. Delivery date and delays

The binding date for delivery is the delivery date given on our orders (date of receipt by ESCHA).

4. Delivery packaging, palletization and weight

4.1 Delivery packaging

- All intact, exchangeable plastic drums (KTG or comparable) are permissible. Alternatively, intact, sturdy wooden reels (one-way / returnable, e.g. KTG) can be used for delivery.
- The stranding/colour sequence refers to the start of the drum (see figure).
- The stranding/colour sequence is provided on the applicable technical data sheet. The stranding/colour sequence specified there must be complied with in every case.
- No more than 4 cables can be started on each cable drum. The cables must be connected by heat shrink tubes of different colours.
- Environmentally friendly foils or similar suitable materials, are used as an intermediate layer, to be used between the drum core and the material to be wound.
- The cables must be delivered to ESCHA sorted/packed by type and color on the pallets.
- The UL labels must be attached to every smallest delivery unit.
- Batch numbers must be clearly visible on the drum labels.
- It must also be clear from the drum labels, whether it is a deposit drum and who has to receive the drum back after consumption.
- It is not permissible to attach advertising media.
- The drum can be wound to a maximum of 80 mm from the flange edge. Sufficient ground clearance must be ensured.

- The following dimensions and weights must never be exceeded:

- Maximum diameter of the reel is 800 mm
- Maximum weight per reel / drum is 80 kg
- Maximum cable drum width is 450 mm

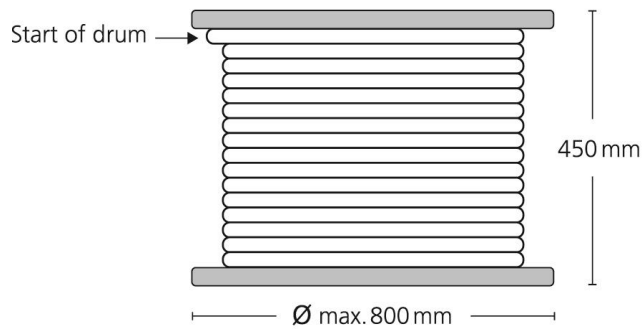

- In some cases, products can be delivered with other parameters after special approval by the general manager of production.

- Maximum diameter of the reel is 1000 mm. Do not exceed the maximum height (including the load carrier) of 1,150 mm.
- Maximum weight per reel / drum is 500 kg
- Maximum cable drum width is 680 mm

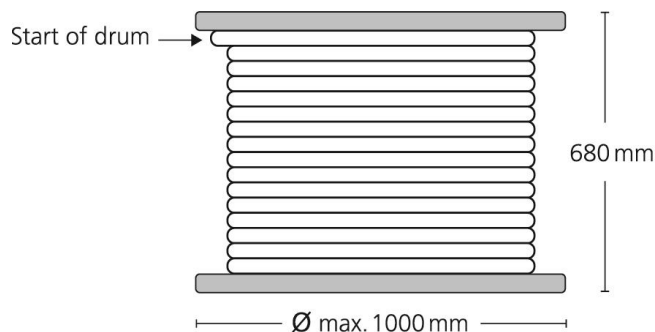

- On each reel / drum the cable must be protected against damage with suitable cardboard or foil.
- Wooden reels (one-way / returnable) must be secured against damage during transport with suitable spacers or blocks (see figures).



- Each reel / drum must be labelled clearly and visibly with the ESCHA item number, ESCHA order number and delivery quantity (metre / weight).
- Old (invalid) stickers, tags or labels must be removed.

4.2 Palletization | load carriers

- Permissible load carriers are Euro pallets that are suitable for high-bay storage, intact and exchangeable (see provisions of EPAL / GPAL), in accordance with UIC 435-2 (1,200 x 800 mm) with the RAL-RG 993 quality mark and which have been treated in accordance with the IPPC standard procedure.
- Alternatively, one-way pallets in conformity with RAL-RG 993 can be used, as long as they are suitable for high-bay storage, secured for transport, intact, dry, and clean. The maximum permissible dimensions of the pallets are 1,200 x 1,000 mm.
- The maximum permissible packaging height including the load carrier is 1,100 mm.
- The goods must be secured for transport and protected against influences from weather.
- The total permissible weight of a pallet is 600 kg.
- Pallets or load carriers with the following characteristics will not be accepted:
 - A bottom or top board is splintered so that more than one nail or screw shank is visible.
 - One or more boards are missing.
 - A spacer block is splintered so that more than one nail or screw shank is visible.
 - A board is broken crosswise or diagonally.
 - More than two bottom or top boards are splintered so that more than one nail or screw shank is visible.

Poor general condition:

- The load-bearing capacity is no longer given (rotten, soft, excessive splintering).
- Excessively dirty condition, which would cause the product to become dirty.
- Excessive splintering on several spacer blocks.
- Impermissible materials have obviously been used (such as boards that are too thin, spacer blocks that are too small).

4.3 Loading of the pallets

- For better handling, only drums of the same size may be loaded on each pallet, in compliance with the maximum load capacity.

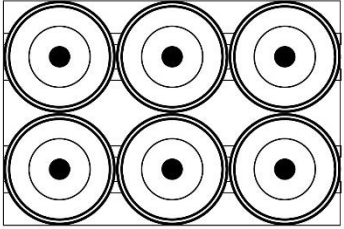
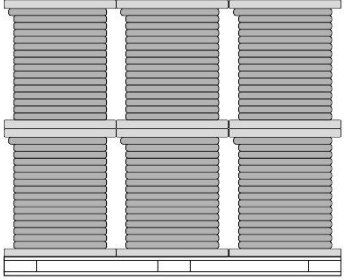
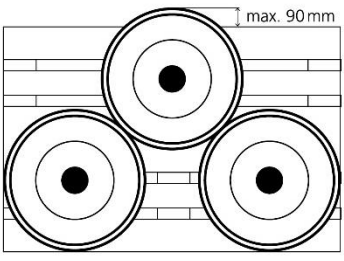
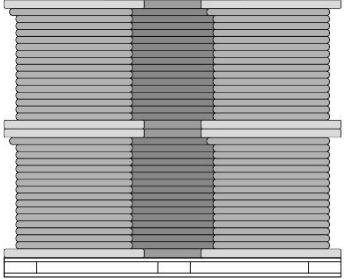
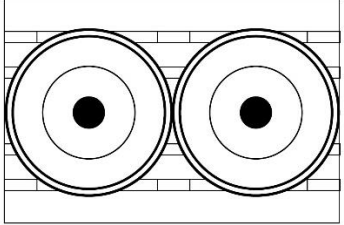
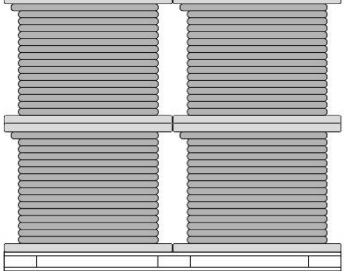
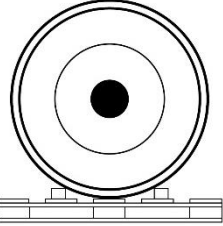
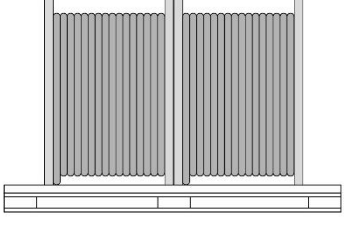
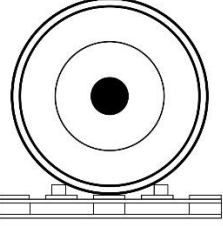
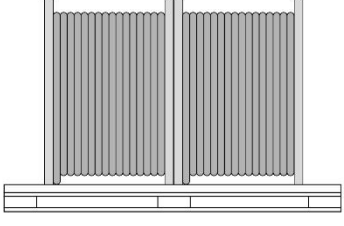
Ø (mm) to	Loading		
0 – 400 max. 80 kg			Standard
401 – 500 max. 80 kg			Standard
501 – 600 max. 80 kg			Standard
601 – 800 max. 80 kg			Standard
801 - 1000			Concessions

- The return of empty one-way/returnable cable drums must be arranged on an individual basis.

5. Delivery note

- Our ESCHA order number and our item number must be specified on every delivery note. If there is a part delivery, then this must also be made clear.
- Your batch numbers must be clearly visible printed on your delivery note document and assigned to the shipment.
- Delivery notes and packing lists must be attached so they are protected and cannot be lost, but still easily visible on every load carrier or packaging unit.
- If you also enclose delivery notes or any other documents within the outer packaging, write 'Papers inside' clearly on the outside.

6. Delivery, dispatch type

- The costs and risk of the delivery to the address of ESCHA given in the orders are borne by the supplier.
- If ESCHA should pay the carriage (by contractual agreement), then the goods must be dispatched by DACHSER: Customer number ESCHA 18010490.
- Since 01/10/2010 we do not accept transport invoices from third-party companies under any circumstances. Our customer number must be given on all carriage documents to avoid the transport costs being calculated incorrectly.
- In case of delivery by air freight, the delivery company must be a "regulated agent" in accordance with the LBA Federal Office of Civil Aeronautics.
- ESCHA is a "known consignor" with the certification number DE/KC/01201-01 by the LBA Braunschweig. This certification obligates us to follow this procedure.

7. Document owner

The purchasing department is the owner of these procedural instructions. The purchasing department is solely responsible for decisions regarding changes to instructions as well as the amendment service. The general manager of materials and production of ESCHA GmbH & Co. KG is responsible for approval of the documents and arranges and grants exceptions (contractually).